

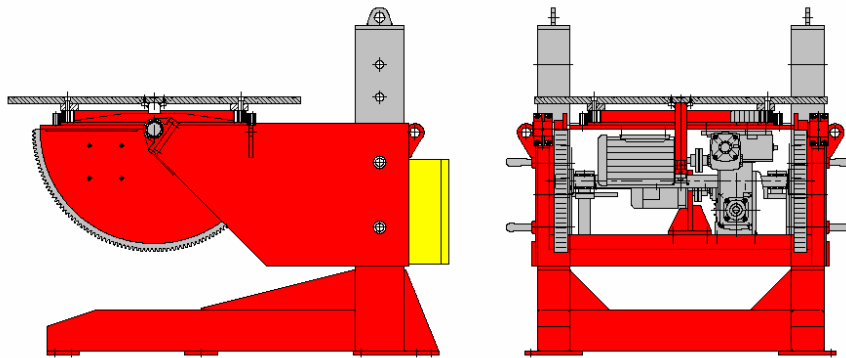

Specification Data
Positioners
Capacity : 5 Tonnes
Adjustable Height
Model: RP5TS

A&N Positioner Model RP5TS Series is a 5 metric tonne capacity designed to give a maximum positioning benefit by using tilt and rotation of the table for easy positioning of the workpiece. Two robust columns permits the operator to adjust the vertical height manually in increments of 150 mm per slot/pitch to give a minimum table height of 1350mm up to maximum table height of 1950mm. The table is machined with four radial slots for anchor bolts and centric marking on the table and is powered driven by AC motor controlled by the latest inverter control box fitted with remote pendant control to provide stop/start, forward/reverse, tilt and variable speed control. Tilt movement is electrically power driven by 2.2KW AC motor with Dynamic Braking through the reduction gearbox. Earth connections are made through a rotary earth clamp to ensure good earthing to the welding power source.



Specifications

Model:	RP5TS- FA-D1500
Table Size:	Diameter of 1500mm
Pendant Control:	24VAC circuit, push button with 6metre cable
Input voltage:	400V/3phase/16amps/50Hz (Specify voltage requirement when ordering)
Turning Capacity:	5-metric ton at 300mm (refer load chart)
Rotation Speed:	0.08 to 0.8rpm
Tilting Capacity:	3-metric ton at 300mm (refer load chart)
Tilt Range:	0 to 135 Degrees
Tilt Speed:	135 Degree at 113second
Rotation Drive Motor:	2.2 KW motor
Rotation Drive Control:	2.2 KW AC inverter
Tilt Drive Motor:	2.2KW c/w brake

..... www.anplant.com

RP5TS Series (5 Tonne)

Dimensions

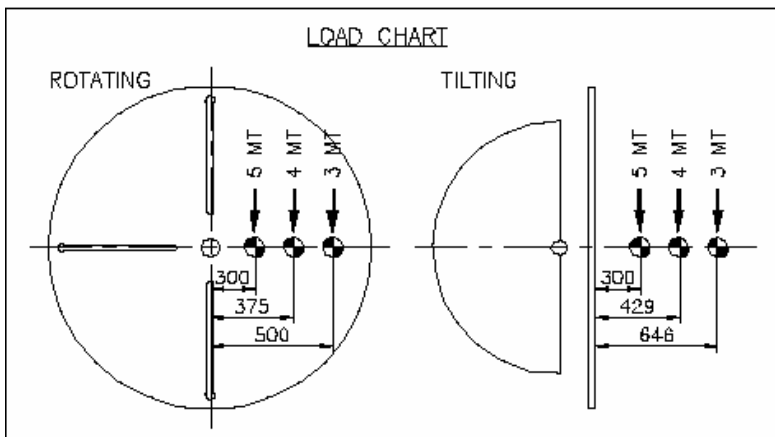
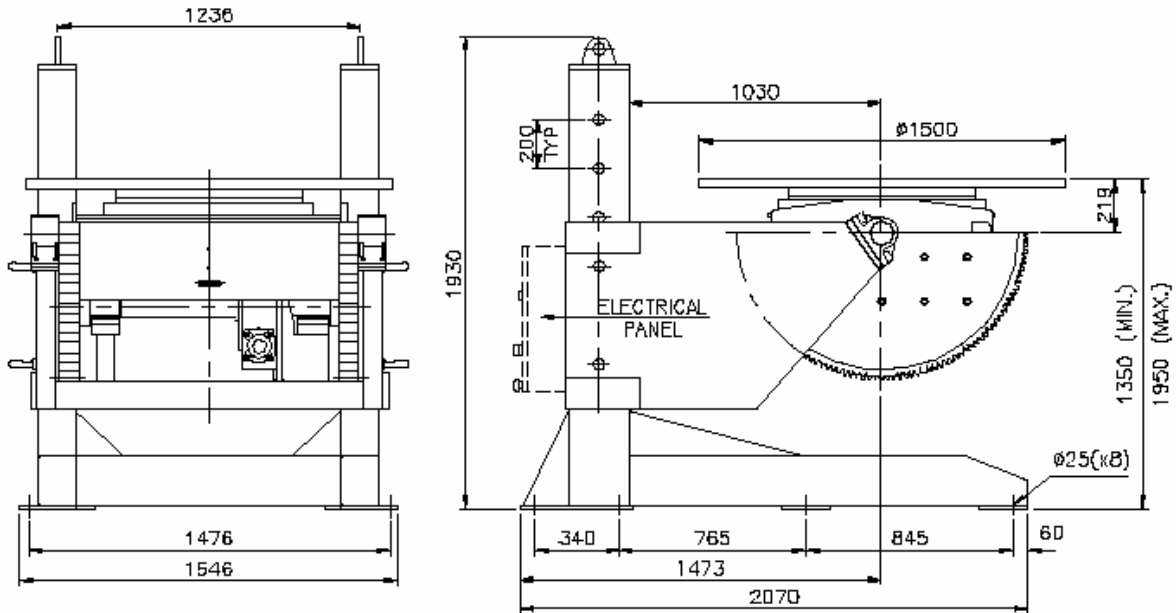

Optional Item

Following optional items are available and have to be factory installed:-

- Encoder
- Tachometer
- Foot Switch

..... www.anplant.com

RP5TS Series (5 Tonne)

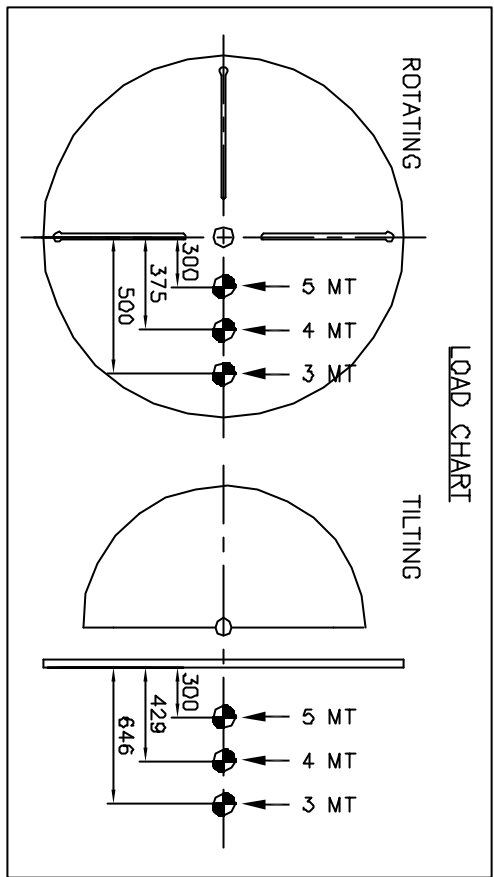

Specification for Positioner

1	Model	RP5TS-FA-D1500
2	Capacity (Turning)	5MT @300rpm (Please refer to Load Chart)
3	Capacity (Tilting)	5MT @300rpm (Please refer to Load Chart)
4	Electrical Panel	Yes
5	Rotation Speed	0.08~0.8rpm at 5~50Hz
6	Tilt Range	0~135 Degrees
7	Incoming Supply	400V-3P-50Hz
8	Control Voltage	24VAC
9	Rotation Drive Control	2.2kW AC Inverter
10	Control Means	Via Push Button Pendant c/w 6m Cable and Foot Switch c/w 6m Cable(OPTION)
11	Rotation Drive Motor	1 x 2.2kW c/w Force Cooling
12	Tilt Speed	135Deg in 113sec
13	Tilt Drive Motor	1 x 2.2kW c/w Brake
14	Rotary Earth Rating	1200 Amp
15	Surface Preparation	Gritblast to SA2.5
16	Painting	2 coats Zinc Phosphate, 1 coat Polyurethane
17	Color	RAL 3003 Red
18	Qty	To be advise

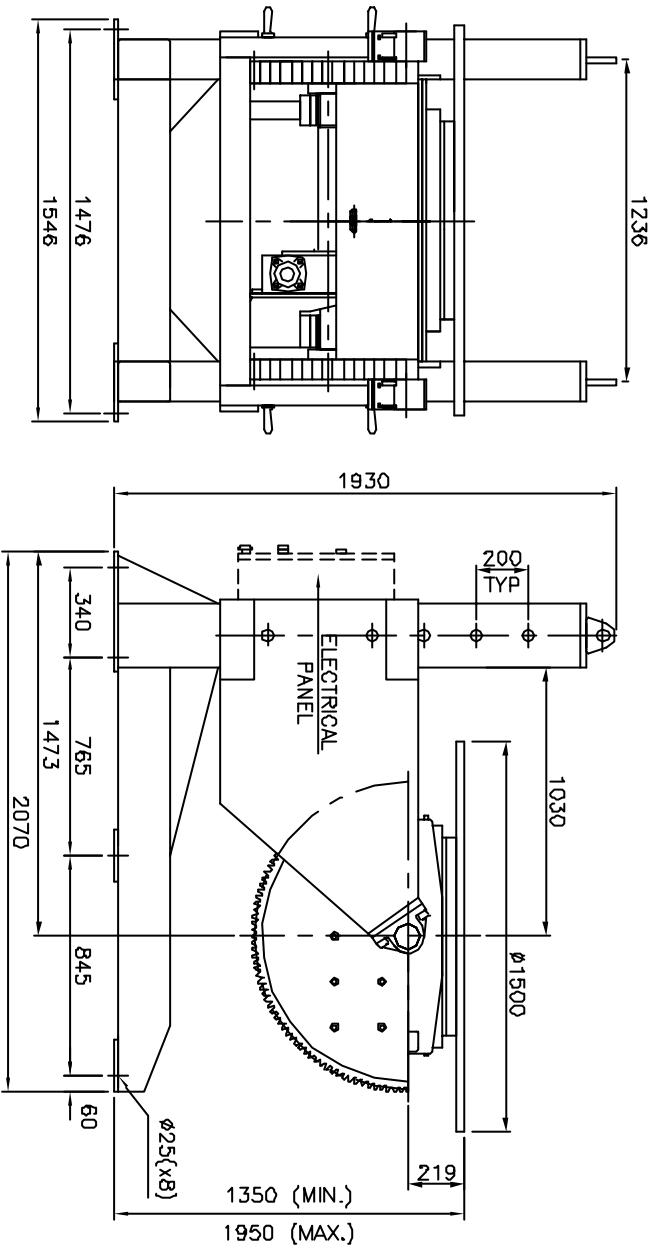

ALL DIMENSIONS IN MM, UNLESS OTHERWISE SPECIFIED.

		PROJECT/MODEL : RP5TS-FA-D1500	
DRAWN : NAME : DATE :	CHECKED : NAME : DATE :	DWG. NAME : POSITIONER	SCALE : N.T.S
APPROVED :	DWG. NO. : SD-RP5TS-FA-D1500	GENERAL ARRANGEMENT	REVISION : 0
THE ORIGINAL AND ALL COPIES OF THIS DRAWING TOGETHER WITH THE COPYRIGHT THEREOF ARE THE SOLE PROPERTY OF RAPE, PTE LTD, SINGAPORE.			