

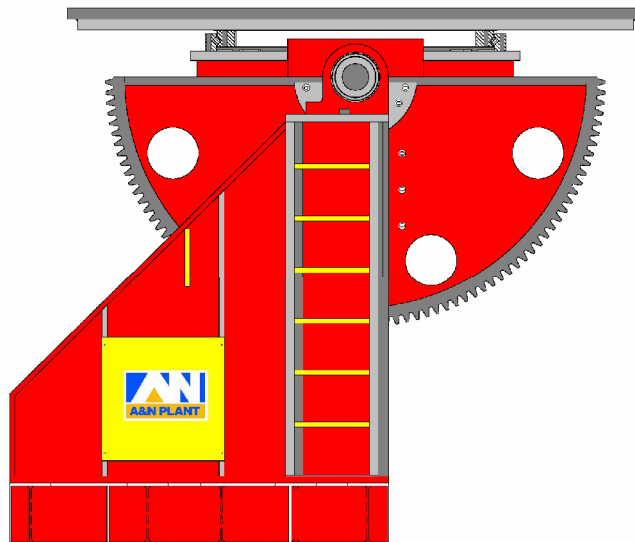

Specification Data
Positioners
Capacity: 35 Tonnes
Model: RP35T

A&N Positioner Model RP35T Series is a 35 metric tonne capacity machine designed to give maximum positioning benefit by using tilt and rotation of the table for easy positioning of the workpiece. Positioner provides 45 degree reverse tilt and 90 degree forward tilt from the 'table flat' or horizontal position. The table is machined with radial slots for anchor bolts and centric marking on the table and is powered driven by AC motor controlled by the latest inverter control box fitted with remote pendant control to provide stop/start, forward/reverse, tilt and variable speed control. Tilt movement is electrically power driven by 7.5Kw AC motor with Dynamic Braking through the reduction gearbox. Earth connections are made through a rotary earth clamp to ensure good earthing to the welding power source.



Specifications

Model:	RP35T-EA-S2800
Table Size:	Diameter of 2800mm
Pendant Control:	24VAC circuit, push button with 6metre cable
Input voltage:	415V/3phase/16amps/50Hz (Specify voltage requirement when ordering)
Rotation Capacity:	35 metric ton @ 300mm
Rotation Speed:	0.029 to 0.29 rpm (or specify)
Tilting Capacity:	35 metric ton at 300mm
Tilt Range:	-30/+90 degrees
Tilt Speed:	90 Degree in 105 second
Rotation Drive Motor:	11 Kw motor
Rotation Drive Control:	11 Kw AC inverter
Tilt Drive Motor:	7.5Kw motor c/w brake
Table:	2800mm square

..... www.anplant.com

RP35T Series (35 Tonnes)

Specification for Positioner

1	Model	RP35T-EA-S2800
2	Capacity	35 Metric Tons
3	Table Size	Sq 2800mm
4	Rotation Speed	0.029~0.29rpm running at 5~50Hz
5	Tilt Speed	90° in 105 sec
6	Tilt Range	+90° ~ -30°
7	Electrical Panel	Yes
8	Incoming Supply	415V-3P-50Hz
9	Control Voltage	24Vac
10	Rotation Drive Control	11KW AC Inverter
11	Rotation Drive	AC 11KW 4P c/w Forced Cooling
12	Tilt Drive	AC 7.5KW 6P c/w Brake
13	Control Means	Via Push Button Pendant c/w 10m Cable
14	Surface Preparation	Gritblast to SA2.5
15	Painting	2 coats Zinc Phosphate, 1 coat Polyurethane
16	Color	RAL 3003 Red
17	Qty	T.B.A.

Loading Chart

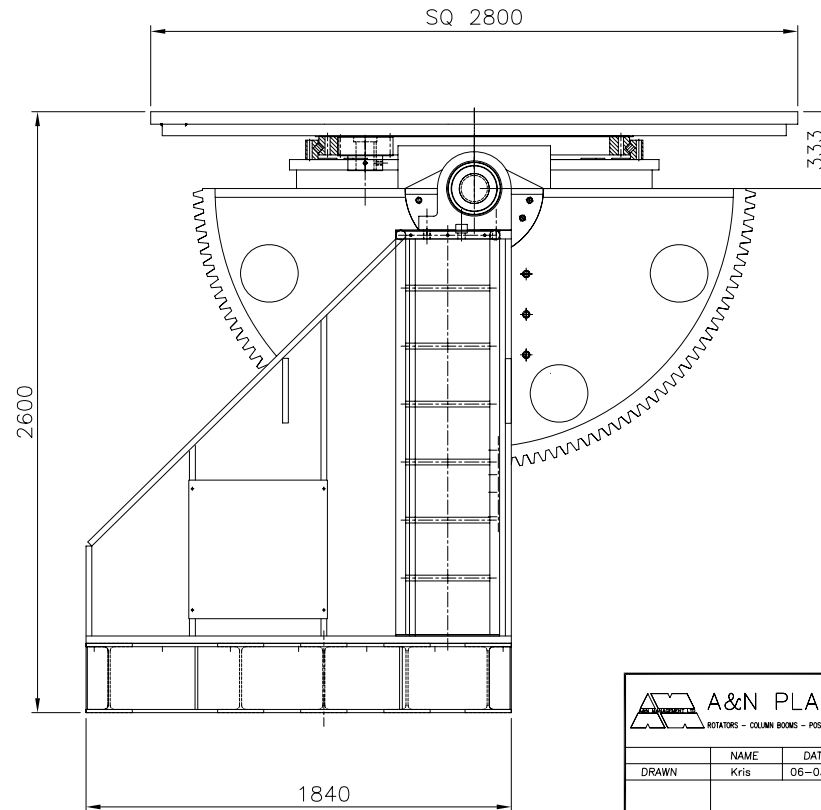
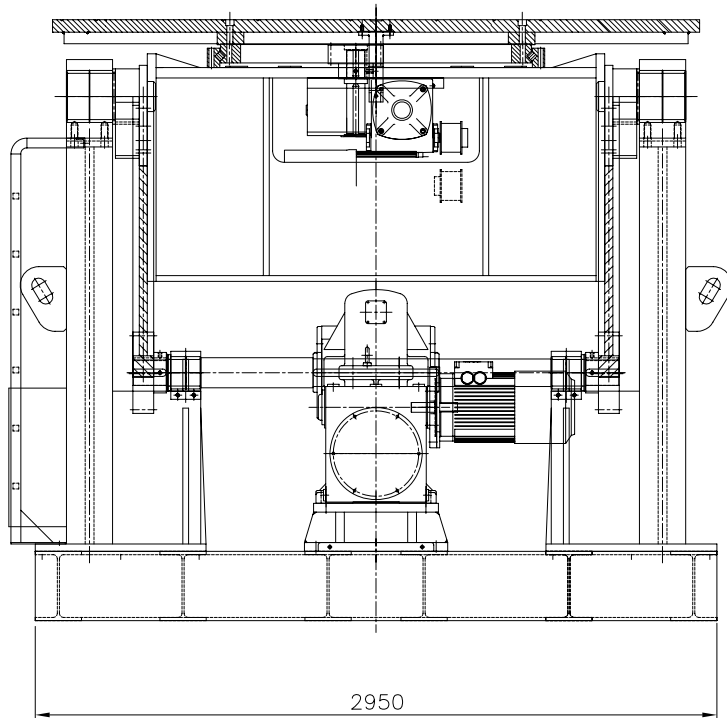
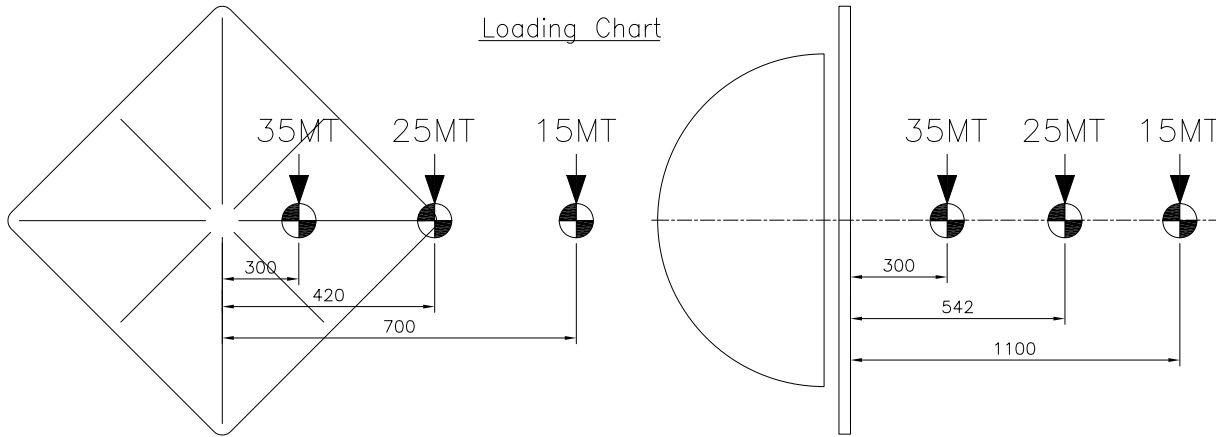

ALL DIMENSIONS IN MM, UNLESS OTHERWISE SPECIFIED.

 A&N PLANT ROTATORS - COLUMN BOOMS - POSITIONERS		PROJECT/MODEL : RP35T-EA-S2800	
DRAWN : NAME : Kris DATE : 06-03-06		CLIENT : -	
APPROVED :		DWG. NAME : POSITIONER GENERAL ARRANGEMENT	
		DWG. NO. : SD-RP35T-EA-S2800	
		SCALE: N.T.S.	
		REVISION: 0	
		SHEET NO: 1 OF 1	
THE ORIGINAL AND ALL COPIES OF THIS DRAWING TOGETHER WITH THE COPYRIGHT THEREOF ARE THE SOLE PROPERTY OF R.P.E. PTE. LTD. SINGAPORE			