



**Specification Data**  
**Conventional Rotators**  
**Capacity: 60/100 Tonnes**  
**MODEL: PR60/100DM**

**A&N** rotators are a robust heavy duty design built to withstand the harsh and rugged environments expected in the world of welding and fabrication requirements. Our proven design uses 520mm diameter 356mm width, replaceable hard-wearing polyurethane tyres mounted onto a cast steel drum for maximum durability and superior traction.

The powered drive unit drives all wheels synchronized using the AC gear motors via the latest inverter control. A hand held low voltage control pendant on a 15-metre cable provides the operator with full control of the rotator including a potentiometer for varying the speed, forward/reverse and stop.

All **A&N** rotators are grit blasted to SA 2.5 for all structural steel and polyurethane paintwork ensuring that your investment provides you with many years of reliable, trouble-free use.

The idler roll has the same dimension to match the powered drive unit. See GA drawing attached.

**Power rolls specifications**

Model:	PR 60/100 DM
Load Capacity:	60 Metric ton (1 power & 1 idler)
Rotation Capacity:	100 metric ton (1 power)
Rotation Speed:	130 to 1295mm/min
Vessel diameter:	Min 995mm to Max 6193mm (at 3100mm C-C) @ 55 degree included angle
Incoming supply:	380-480V/3Phase/16Amps/48/62/hz. (Specify input voltage when ordering)
AC Inverter:	3KW inverter system
Motor rating:	1.5KW x 2
Control voltage:	DC 24 Volt control circuit.
Weight:	2080Kg Drive Unit 1210Kg Idler Unit

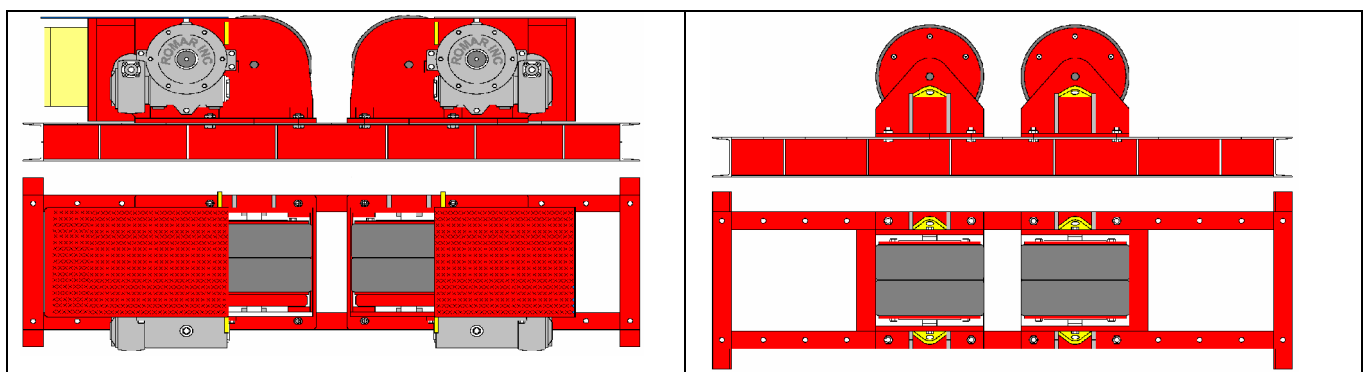

..... [www.anplant.com](http://www.anplant.com) .....

PR60/100DM (60 Tonnes) rev 1 23.8.06

**Guidelines for Vessel Diameter in mm ( D )**

CC (mm)	Included Angle, q (in deg)												
	30	35	40	45	50	55	60	65	70	75	80	85	90
700	2184	1807	1526	1308	1136	995	879	782	700	629	568	515	469
1100	3729	3137	2695	2354	2082	1862	1679	1527	1397	1286	1191	1108	1035
1500	5275	4468	3865	3399	3029	2728	2479	2271	2094	1943	1813	1700	1601
1900	6820	5798	5035	4444	3975	3594	3279	3016	2792	2600	2435		
2300	8366	7128	6204	5489	4922	4460	4079	3760	3489	3257			
2700	9911	8458	7374	6535	5868	5327	4879	4504					
3100	11457	9788	8543	7580	6815	6193	5679						

**Vessel Clearance from Skid in mm ( C )**

CC (mm)	Included Angle, q (in deg)												
	30	35	40	45	50	55	60	65	70	75	80	85	90
700	519	511	503	495	487	479	471	463	455	446	438	429	420
1100	493	480	468	456	443	430	418	405	392	378	365	351	337
1500	466	450	433	416	399	381	364	346	329	310	292	273	254
1900	440	419	397	376	354	333	310	288	265	243	219		
2300	414	388	362	336	310	284	257	230	202	175			
2700	387	357	327	296	266	235	203	172					
3100	361	326	292	257	221	186	150						

**Overall Vessel Height in mm ( H )**

CC (mm)	Included Angle, q (in deg)												
	30	35	40	45	50	55	60	65	70	75	80	85	90
700	2903	2518	2229	2004	1823	1675	1551	1445	1354	1275	1206	1144	1089
1100	4422	3818	3364	3009	2725	2492	2297	2131	1989	1865	1755	1659	1572
1500	5941	5117	4498	4015	3627	3309	3043	2817	2623	2454	2305	2173	2055
1900	7460	6417	5632	5020	4529	4127	3790	3504	3257	3043	2854		
2300	8979	7716	6766	6026	5432	4944	4536	4190	3892	3632			
2700	10499	9015	7901	7031	6334	5761	5283	4876					
3100	12018	10315	9035	8037	7236	6579	6029						

**Note:**

1. This chart is applicable to A&N ROTATOR using diameter 520mm (201/2") tyres.
2. Recommended Included Angle should **always** be greater the 45 degree unless vessel is true concentric.
3. Shaded portion is not recommended.

..... [www.anplant.com](http://www.anplant.com) .....

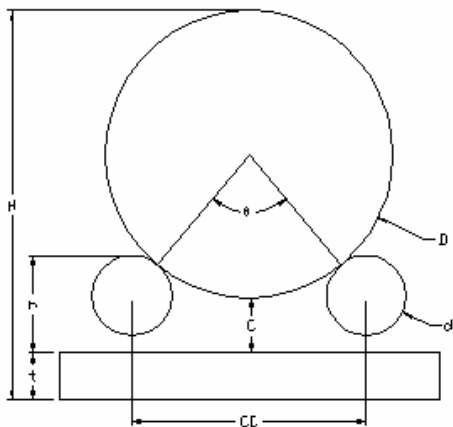

Roller Dia. (d) = 520.7 mm  
 Roller Ht. from Skid (h) = 565 mm  
 Skid Ht. (t) = 200 mm

**Ordering Information and system checklist**

Equipment	Part Number	Description
Rotator	PR60/100DM-	60-metric ton loading capacity / 100-metric ton turning capacity
Built-in with	EA-	3-phase AC motor, Pendant control with 15m cable.
Base Frame Length Center to Center	3100-	Base frame maximum center to center distance 3100mm(C-C)

**Optional item**

Devices	AC- ACM- Y-	Anti-creep device manual Anti-creep device motorized Lead-screw type C-C adjustment
Travel car	TC- TCM-	Travel car Manual Travel car Motorized

We reserve the right to alter specifications without prior notice

..... [www.anplant.com](http://www.anplant.com) .....



PR60/100DM (60 Tonnes) rev 1 23.8.06

Specification for Rotator

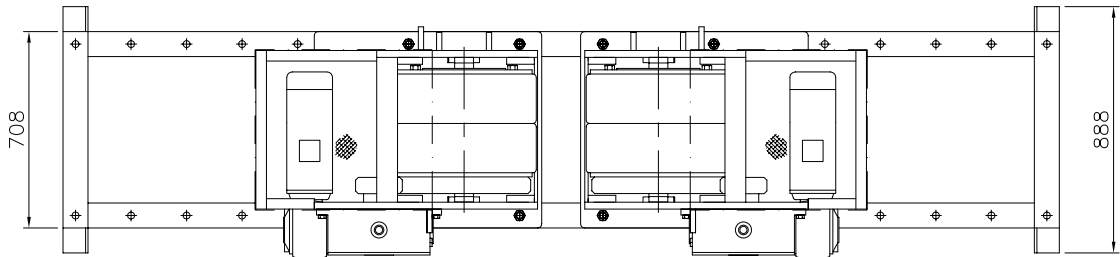
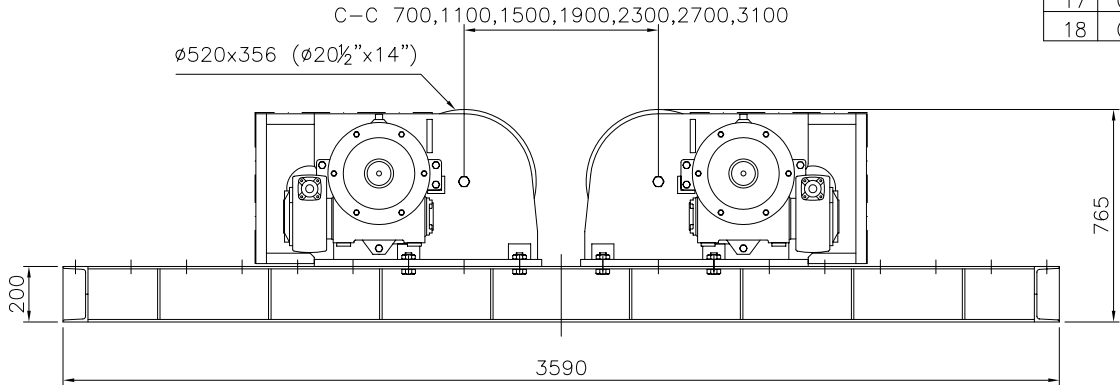
1	Model	PR60/100DM-EA-3100
2	Capacity (Loading)	30 TON
3	Capacity (Turning)	100 TON
4	Vessel Size (Min.)	ø466mm at 90° Included Angle
5	Vessel Size (Max.)	ø11457mm at 30° Included Angle ø7580mm at 45° Included Angle ø5679mm at 60° Included Angle
6	Electrical Panel	Yes
7	Roller Speed	130 to 1295mm/min at 5 to 50Hz
8	Incoming Supply	400V-3P-50/60Hz
9	Control Voltage	24 Vdc
10	Roller Drive Control	3 KW AC Inverter
11	Control Means	via Push Button on Pendant clw 10m cable
12	Roller Drive Motor	2 x AC 1.5KW c/w Force Cooling
13	Travelcar (Bogie)	N.A.
14	Travelcar Speed	N.A.
15	Surface Preparation	Gritblast to SA2.5
16	Painting	2 coats Zinc Phosphate, 1 coat Polyurethane
17	Color	RAI 3003 Red
18	Qty	T.B.A





ALL DIMENSIONS IN MM, UNLESS OTHERWISE SPECIFIED.

 <b>A&amp;N PLANT</b> <small>ROTATORS - COLUMN BOOMS - POSTIONERS</small>			PROJECT/MODEL : PR60/100DM-EA-3100	
CLIENT : -			 SCALE: N.T.S.	
DRAWN Kris	NAME Kris	DATE 18-05-05		
APPROVED			DWG. NO. : SD-PR60/100DM-EA-3100	
			REVISION: 0	
			SHEET NO: 1 OF 1	
THE ORIGINAL AND ALL COPIES OF THIS DRAWING TOGETHER WITH THE COPYRIGHT THEREOF ARE THE SOLE PROPERTY OF R.P.E. PTE. LTD. SINGAPORE				

### Specification for Rotator

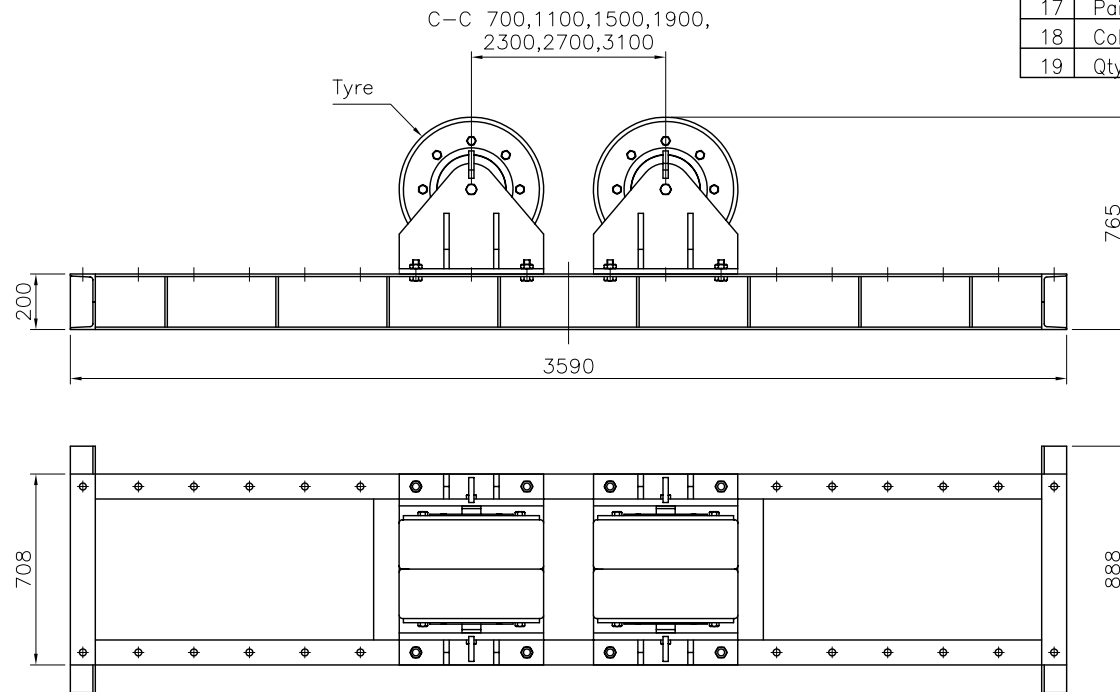
1	Model	IR60-3100
2	Capacity (Loading)	30 metric tons
3	Capacity (Turning)	N.A.
4	Vessel Size (Min.)	ø466mm at 90° Included Angle
5	Vessel Size (Max.)	ø11457mm at 30° Included Angle ø7580mm at 45° Included Angle ø5679mm at 60° Included Angle
6	Tyre Type and Size	Polyurethane, ø20.5"x14"
7	Electrical Panel	N.A.
8	Roller Speed	N.A.
9	Incoming Supply	N.A.
10	Control Voltage	N.A.
11	Roller Drive Control	N.A.
12	Control Means	N.A.
13	Roller Drive Motor	N.A.
14	Travelcar (Bogie)	N.A.
15	Travelcar Speed	N.A.
16	Surface Preparation	Gritblast to SA2.5
17	Painting	2 coats Zinc Phosphate, 1 coat Polyurethane
18	Color	RAL 3003 Red
19	Qty	T.B.A



 <b>A&amp;N PLANT</b> ROTATORS - COLUMN BOOMS - POSITIONERS		PROJECT/MODEL :		IR60-3100
		CLIENT :		
DRAWN	NAME	DATE	DWG. NAME : ROTATOR GENERAL ARRANGEMENT	
	Kris	08-04-05		
APPROVED			DWG. NO. : SD-IR60-3100	
			SCALE: N.T.S.	
			REVISION: 0	
			SHEET NO: 1 OF 1	
THE ORIGINAL AND ALL COPIES OF THIS DRAWING TOGETHER WITH THE COPYRIGHT THEREOF ARE THE SOLE PROPERTY OF R.P.E. PTE. LTD. SINGAPORE				



ALL DIMENSIONS IN MM, UNLESS OTHERWISE SPECIFIED.

Specification for Rotator

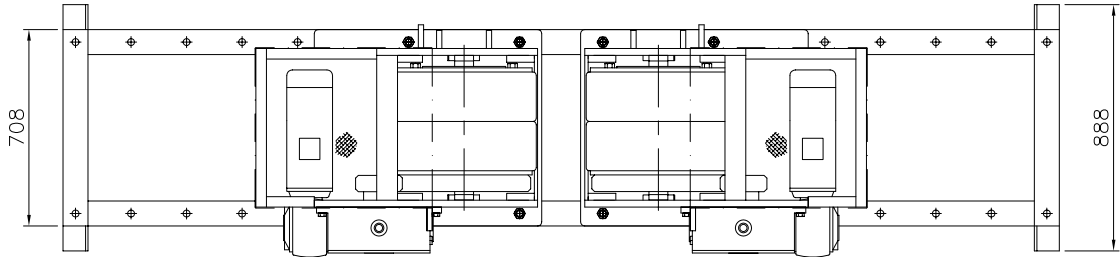
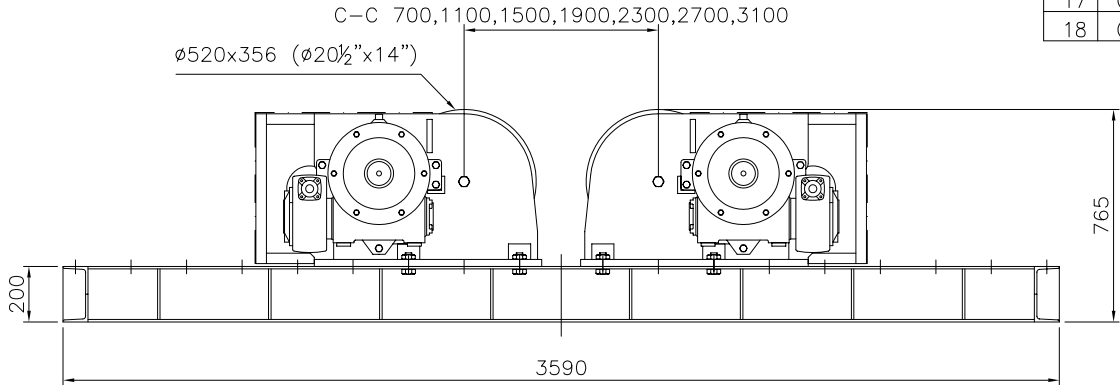
1	Model	PR60/100DM-EA-3100
2	Capacity (Loading)	30 TON
3	Capacity (Turning)	100 TON
4	Vessel Size (Min.)	ø466mm at 90° Included Angle
5	Vessel Size (Max.)	ø11457mm at 30° Included Angle ø7580mm at 45° Included Angle ø5679mm at 60° Included Angle
6	Electrical Panel	Yes
7	Roller Speed	130 to 1295mm/min at 5 to 50Hz
8	Incoming Supply	400V-3P-50/60Hz
9	Control Voltage	24 Vdc
10	Roller Drive Control	3 KW AC Inverter
11	Control Means	via Push Button on Pendant clw 10m cable
12	Roller Drive Motor	2 x AC 1.5KW c/w Force Cooling
13	Travelcar (Bogie)	N.A.
14	Travelcar Speed	N.A.
15	Surface Preparation	Gritblast to SA2.5
16	Painting	2 coats Zinc Phosphate, 1 coat Polyurethane
17	Color	RAI 3003 Red
18	Qty	T.B.A





ALL DIMENSIONS IN MM, UNLESS OTHERWISE SPECIFIED.

 <b>A&amp;N PLANT</b> <small>ROTATORS - COLUMN BOOMS - POSTIONERS</small>			PROJECT/MODEL : PR60/100DM-EA-3100	
CLIENT : -			 SCALE: N.T.S.	
DRAWN Kris	NAME Kris	DATE 18-05-05		
APPROVED			DWG. NO. : SD-PR60/100DM-EA-3100	
			REVISION: 0	
			SHEET NO: 1 OF 1	
THE ORIGINAL AND ALL COPIES OF THIS DRAWING TOGETHER WITH THE COPYRIGHT THEREOF ARE THE SOLE PROPERTY OF R.P.E. PTE. LTD. SINGAPORE				

### Specification for Rotator

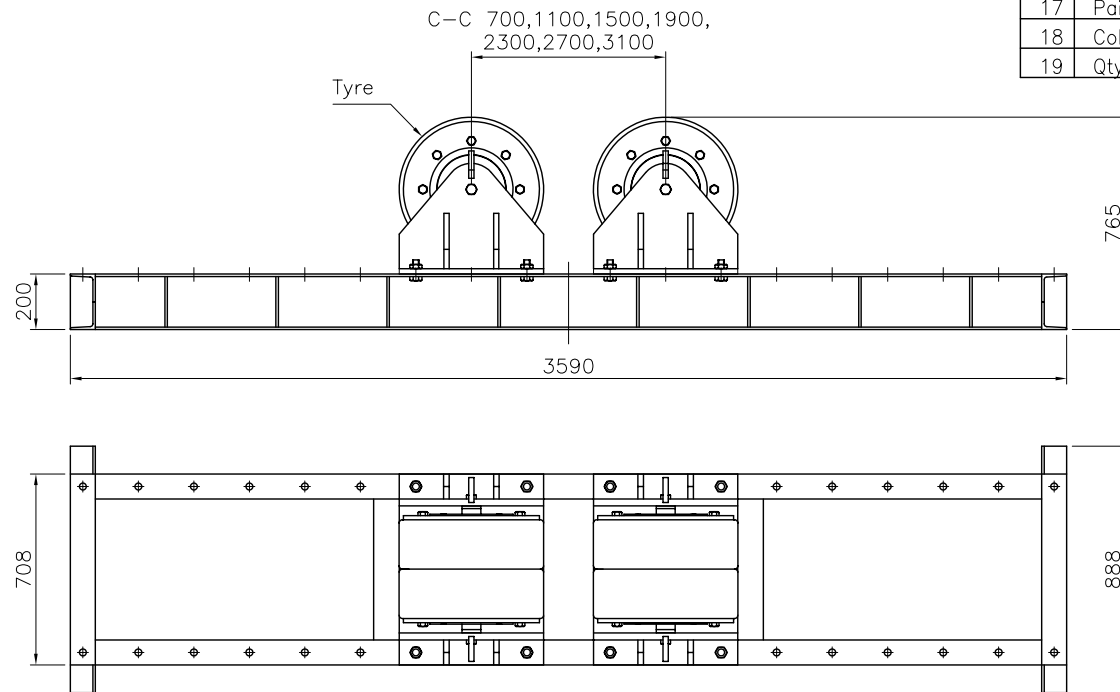
1	Model	IR60-3100
2	Capacity (Loading)	30 metric tons
3	Capacity (Turning)	N.A.
4	Vessel Size (Min.)	ø466mm at 90° Included Angle
5	Vessel Size (Max.)	ø11457mm at 30° Included Angle ø7580mm at 45° Included Angle ø5679mm at 60° Included Angle
6	Tyre Type and Size	Polyurethane, ø20.5"x14"
7	Electrical Panel	N.A.
8	Roller Speed	N.A.
9	Incoming Supply	N.A.
10	Control Voltage	N.A.
11	Roller Drive Control	N.A.
12	Control Means	N.A.
13	Roller Drive Motor	N.A.
14	Travelcar (Bogie)	N.A.
15	Travelcar Speed	N.A.
16	Surface Preparation	Gritblast to SA2.5
17	Painting	2 coats Zinc Phosphate, 1 coat Polyurethane
18	Color	RAL 3003 Red
19	Qty	T.B.A



 <b>A&amp;N PLANT</b> ROTATORS - COLUMN BOOMS - POSITIONERS			PROJECT/MODEL :	
			IR60-3100	
DRAWN			NAME	DATE
Kris			Kris	08-04-05
APPROVED			CLIENT :	
			-	
			DWG. NAME : ROTATOR GENERAL ARRANGEMENT	
			DWG. NO. : SD-IR60-3100	
				
			SCALE: N.T.S.	
			REVISION: 0	
			SHEET NO: 1 OF 1	
THE ORIGINAL AND ALL COPIES OF THIS DRAWING TOGETHER WITH THE COPYRIGHT THEREOF ARE THE SOLE PROPERTY OF R.P.E. PTE. LTD. SINGAPORE				

ALL DIMENSIONS IN MM, UNLESS OTHERWISE SPECIFIED.